

PYXIS
AVIATION
GROUP
navigating the deal



SPECIFICATIONS - As of Aug 2024

GULFSTREAM

G650 SN6350





DELIVERY YEAR

2019



TOTAL TIME

1,630



LANDINGS

507

HIGHLIGHTS

- > Engines and APU on JSSI
 - > Impeccable interior
- > Secureplane HD Camera System
 - > Electric Pocket Door
 - > Inmarsat KA Band Wifi

SPECIFICATION 2019 GULFSTREAM G650

Airframe	
Serial Number	6350
Delivery Year	2019
Registration	9H-CAA
Certification	EASA Part-145 Ops
Total Airframe Hours	1,630
Landings	507
Location	Europe

Engines		
Rolls-Royce BR700-725A1-12		
	ENGINE 1	ENGINE 2
Serial Number	25811	25810
TSN	1,630	1,630
CSN	507	507
Engine Program	JSSI	

APU	
Honeywell RE220	
SN	P463
TSN	1,493
CSN	-
APU Program	JSSI

Avionics	
ADF	Honeywell DF-855
AVIONICS PACKAGE	Gulfstream PlaneView; Honeywell Primus Epic
COMMUNICATION RADIOS	Dual Honeywell TR-866B
CVR	Universal Avionics
DME	Dual Honeywell DM-855
FMS	Triple NextGen
FDR	DFDR
HI-FREQUENCY	Dual Collins HF-9034A w/SELCAL
IRS	Triple Honeywell LASEREF VI
NAVIGATION RADIOS	Dual Honeywell NV-878A
RADAR ALTIMETER	Dual Honeywell KRA-405B
SATCOM	Honeywell HD-710 Inmarsat
SATPHONE	AirCell Exxess II ST-4200 Iridium
TCAS	Honeywell TPA-100 w/change 7.1
TRANSPONDER	Dual Honeywell XS-858B
WEATHER RADAR	Honeywell TR-1 w/predictive windshear

Compliance
ADS-B Out
EASA CAT Ops Compliant
RNP 5
FANS-1/A+
CPDLC

SPECIFICATION 2019 GULFSTREAM G650



Additional Equipment
EVS II
HUD II

Interior	
Configuration	Executive / 14 Passengers
Interior	2019 (in great condition)
Forward Cabin	4 x Single Club Executive Seats
Mid Cabin	4 x Single Club Executive Seats
Aft Cabin	3-Place Divan opposite 3-Place Divan
Galley	Forward Galley including a Convection Oven, Microwave, Cooler, Nespresso Machine, Storage Space and Fine China.
Lavatory	Forward Crew Lavatory Fully-enclosed Executive Aft Lavatory.
Materials and Colours	<ul style="list-style-type: none"> • Seating: Eight executive Townsend leather seats • Carpet: Light Beige Carpet • Cabinetry: Dark Mahony Veneer

Connectivity	Inmarsat KA Band Wifi
Entertainment	Gulfstream PlaneView
Paint Scheme	Matterhorn White with Dark Blue and Baby Blue horizontal designs with waves until empennage.

SPECIFICATION 2019 GULFSTREAM G650 CABIN PLAN VIEW

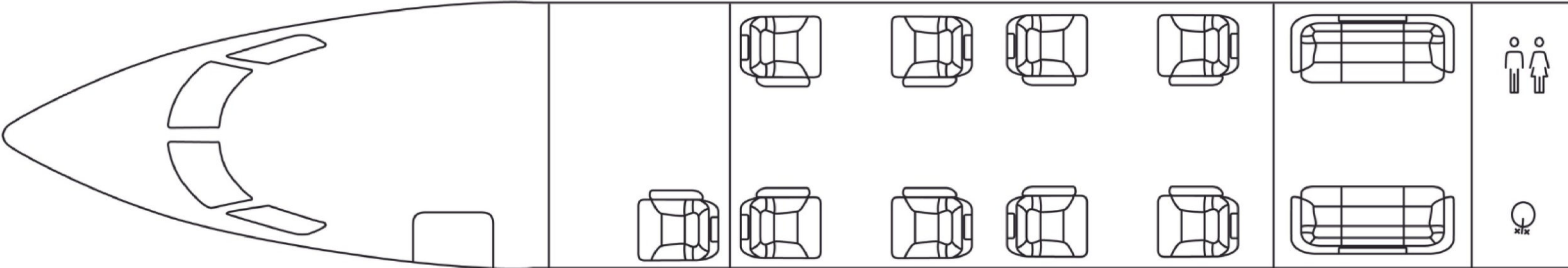

SPECIFICATION 2019 GULFSTREAM G650 CABIN NIGHT VIEW

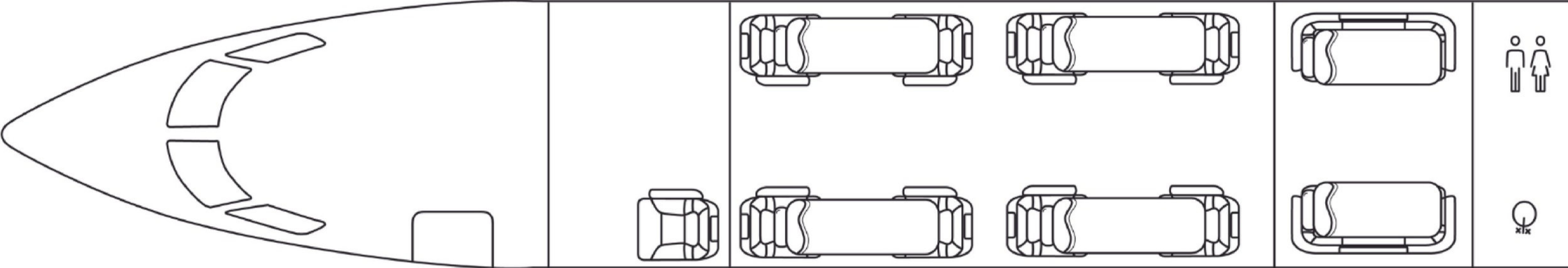

PYXIS
AVIATION
GROUP
navigating the deal



PYXIS
AVIATION
GROUP
navigating the deal



PYXIS
AVIATION
GROUP
navigating the deal



PYXIS
AVIATION

GROUP
navigating the deal





NO SMOKING
IN CABIN
SMOKING PROHIBITED
ALL THE TIME





PYXIS
AVIATION
GROUP
navigating the deal

PYXIS
AVIATION
GROUP
navigating the deal





PYXIS
AVIATION
GROUP
navigating the deal





Contact

Shiloh Saatori
Executive Vice President

Phone: +43 676 83211 717
E-mail: s.saatori@pyxis.aero

www.pyxis.aero

Notes

Specifications, descriptions, terms, and pricing are provided as introductory information only. Interested parties should rely upon their own inspections and examinations of aircraft and their records. This introductory information is subject to changes and/or correction and does not constitute representations or warranties by Pyxis Aviation Group or its clients. This material does not represent a binding offering, and aircraft are subject to prior sale and/or withdrawal from the market at any time.